

FM-4W Technical Data 4-Way Reach Truck

FM-4W 20

FM-4W 25



FM-4W 4-Way Reach Truck

Fully functional in all directions

This specification sheet, which conforms to VDI guideline 2198, provides the technical values for the standard equipment only. Different tyres, other masts, the use of accessories, etc., may result in other values.



	Item No.	Description	Unit	Model			
				FM-4W 20	FM-4W 25		
Distinguishing marks	1.1	Manufacturer		STILL	STILL		
	1.2	Manufacturer's type designation		FM-4W 20	FM-4W 25		
	1.3	Drive		Electric	Electric		
	1.4	Operator type		Seated	Seated		
	1.5	Rated capacity/rated load	Q	kg	2000	2500	
	1.6	Load capacity at load centre distance	c	mm	600	600	
	1.8	Load distance	x	mm	449 ²	527 ³	
	1.9	Wheel base	y	mm	1505	1665	
	Weights	2.1	Service weight incl. battery		kg	4360 ²	4960 ³
2.3		Axle loading, forks in the back, unladen	drive end/load end	kg	2550/1810	2880/2080	
2.4		Axle loading, forks in the front, laden	drive end/load end	kg	800/5560	660/6800	
2.5		Axle loading, forks in the back, laden	drive end/load end	kg	2360/4000	2830/4630	
Tyres/chassis	3.1	Tyres			Vulcollan	Vulcollan	
	3.2	Tyre size	drive end	mm	∅ 355 x 155	∅ 355 x 155	
	3.3	Tyre size	load end, left	mm	∅ 320 x 100	∅ 320 x 100	
	3.3	Tyre size	load end, right	mm	∅ 260 x 85	∅ 260 x 85	
	3.5	Number of wheels (x = driven)	drive end/load end			1x/4	1x/4
	3.7	Tread	load end	mm	1444	1444	
	Dimensions	4.1	Tilt of mast/fork carriage ¹	forward/backward	α/β	°	1.0/1.0
4.2		Height	mast lowered	h ₁	mm	3533	4083
4.3		Free lift		h ₂	mm	2803	3353
4.4		Lift		h ₃	mm	8450	9650
4.5		Height	mast extended	h ₄	mm	9200	10400
4.7		Height of overhead guard (cabin)		h ₆	mm	2215	2215
4.8		Seat height		h ₇	mm	1087	1087
4.10		Height of wheel arms		h ₈	mm	430	430
4.19		Overall length		l ₁	mm	2473 ²	2555 ³
4.20		Length to face of forks		l ₂	mm	1323 ²	1405 ³
4.21		Overall width		b ₁ /b ₂	mm	1744/1498	1744/1498
4.22		Fork dimensions		s/e/l	mm	45/125/1150	45/125/1150
4.24		Fork carriage width		b ₃	mm	1500	1500
4.25		Distance between fork arms	min./max.	b ₅	mm	556/1555	556/1555
4.26		Distance between wheel arms		b ₄	mm	903	903
4.28		Reach distance		l ₄	mm	704 ²	782 ³
4.31		Ground clearance, laden, below mast		m ₁	mm	81	81
4.32		Ground clearance, centre of wheel base		m ₂	mm	80	80
4.34.1		Aisle width for pallets 1000 x 1200 crossways		A _{st}	mm	2787 ²	2896 ³
4.34.2		Aisle width for pallets 800 x 1200 lengthways		A _{st}	mm	2823 ²	2915 ³
4.35		Turning radius		W _a	mm	1772	1932
4.37	Length across wheel arms		l ₇	mm	1942	2102	
Performance data	5.1	Travel speed	laden/unladen	km/h	13.0/13.0	13.0/13.0	
	5.1.1	Travel speed, backwards	laden/unladen	km/h	8.0/11.3	8.0/11.3	
	5.2	Lift speed	laden/unladen	m/s	0.33/0.55	0.32/0.53	
	5.3	Lowering speed	laden/unladen	m/s	0.54/0.47	0.53/0.53	
	5.4	Reaching speed	laden/unladen	m/s	0.20/0.20	0.20/0.20	
	5.8	Gradeability	laden/unladen	%	10/15	9/14	
	5.9	Acceleration time over 10 m	laden/unladen	s	5.7/5.0	6.2/5.2	
	5.10	Service brake			Electric	Electric	
	Electric engine	6.1	Drive motor rating S2 = 60 min		kW	7.2	7.2
		6.2	Lift motor rating S3 = 15 %		kW	15	15
6.3		Battery according to DIN 43531/35/36 A, B, C, no			43531 C	43531 C	
6.4		Battery voltage/nominal capacity K _s		V/Ah	48/465	48/620	
6.5		Battery weight (depending on manufacturer ±5%)		kg	712 ²	892 ³	
Misc.	8.1	Drive control			Electronic	Electronic	
	8.2	Operating pressure for attachments		bar	150	150	
	8.3	Oil volume for attachments		l/min	25	25	
	8.4	Sound pressure level at driver's ear		db (A)	59.7	59.7	

FM-4W 20: l₁ and l₂ increase by 32 mm when the battery tray changes from size C to E; these lengths increase by 72 mm with every further increase in battery size
 FM-4W 25: l₁ and l₂ increase by 47 mm when the battery tray changes from size E to F; these lengths increase by 72 mm with every further increase in battery size

¹ Depends on mast (h₃ ≤ 6300 mm: mast tilt up to 1.5°/3.5°; h₃ > 6700 mm: mast tilt up to 1°/1°)

² With battery tray C (up to 465 Ah)

³ With battery tray E (up to 620 Ah)

FM-4W 4-Way Reach Truck

Technical Drawings

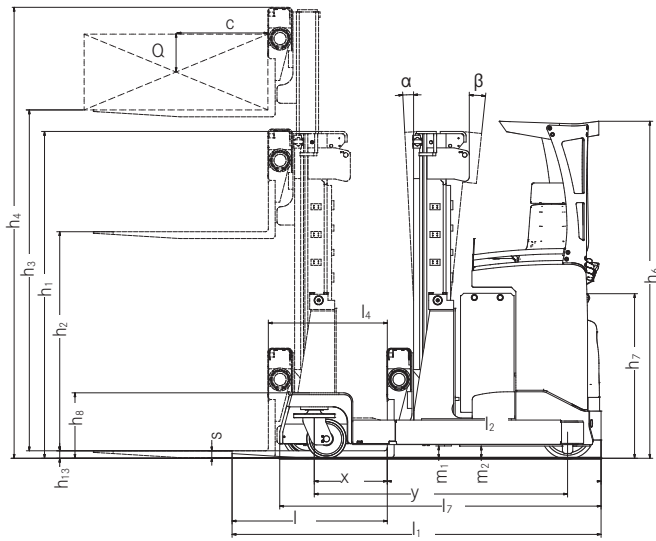

Side view

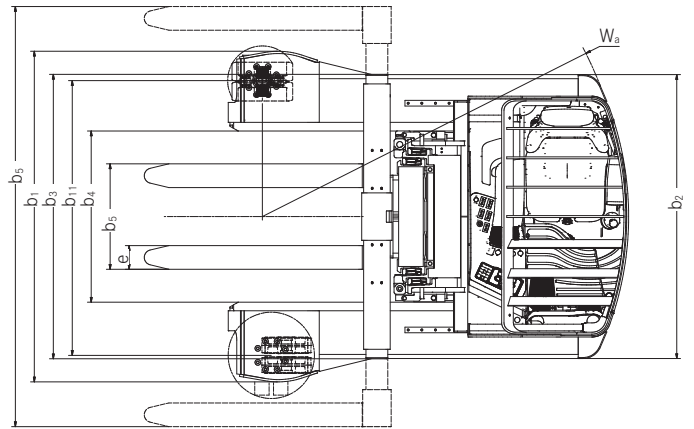

Top view

Basic Load Capacities

Load capacity FM-4W 20

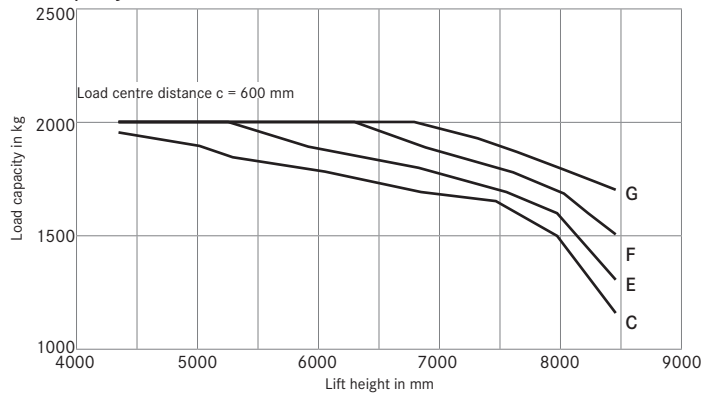

Load capacity FM-4W 25

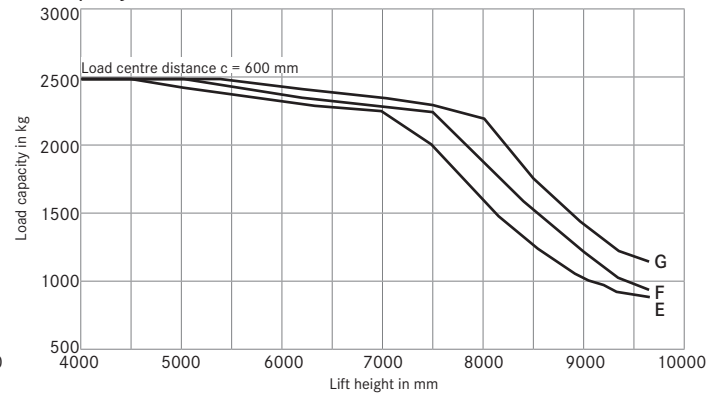

C Battery tray C for 465 Ah battery // E Battery tray E for 620 Ah battery // F Battery tray F for 775 Ah battery // G Battery tray G for 930 Ah battery

Mast Tables

FM-4W 20	Triplex Mast										
	Height, mast lowered	h_1	mm	2,150	2,350	2,450	3,650	2,800	2,967	3,200	3,367
Free lift	h_2	mm	1,420	1,620	1,720	1,920	2,070	2,237	2,470	2,637	2,803
Lift	h_3	mm	4,300	4,900	5,200	5,800	6,250	6,750	7,450	7,950	8,450
Height, mast extended	h_4	mm	5,050	5,650	5,950	6,550	7,000	7,500	8,200	8,700	9,200
Tilt of mast forward/backward	α/β	°	1.5/3.5	1.5/3.5	1.5/3.5	1.5/3.5	1.5/3.5	1.0/1.0	1.0/1.0	1.0/1.0	1.0/1.0

FM-4W 25	Triplex Mast													
	Height, mast lowered	h_1	mm	2,350	2,450	2,650	2,800	2,967	3,200	3,367	3,533	3,683	3,850	3,967
Free lift	h_2	mm	1,620	1,720	1,920	2,070	2,237	2,470	2,637	2,803	2,953	3,120	3,237	3,353
Lift	h_3	mm	4,450	4,750	5,350	5,800	6,300	7,000	7,500	8,000	8,450	8,950	9,300	9,650
Height, mast extended	h_4	mm	5,200	5,500	6,100	6,550	7,050	7,750	8,250	8,750	9,200	9,700	10,050	10,400
Tilt of mast forward/backward	α/β	°	1.5/3.5	1.5/3.5	1.5/3.5	1.5/3.5	1.5/3.5	1.0/1.0	1.0/1.0	1.0/1.0	1.0/1.0	1.0/1.0	1.0/1.0	1.0/1.0

FM-4W 4-Way Reach Truck
Fully functional in all directions



Aisle Widths

FM-4W 20

Load width B = 800 mm Safety clearance: 400 mm			
Aisle A ₁ mm*	Main aisle A ₂ mm*		
	Load length L		
	4 m	6 m	8 m
2,800	2,650	3,390	4,940
3,000	2,650	3,180	4,680
3,200	2,650	2,650	4,440
3,400	2,650	2,650	4,210
3,600	2,650	2,650	4,000
3,800	2,650	2,650	3,790
4,000	2,650	2,650	3,600
4,200	2,650	2,650	3,410
4,400	2,650	2,650	3,240
4,600	2,650	2,650	3,070
4,800	2,650	2,650	2,650
5,000	2,650	2,650	2,650
5,200	2,650	2,650	2,650
5,400	2,650	2,650	2,650

* Depends on battery size

FM-4W 25

Load width B = 800 mm Safety clearance: 400 mm			
Aisle A ₁ mm*	Main aisle A ₂ mm*		
	Load length L		
	4 m	6 m	8 m
2,800	2,670	3,390	4,940
3,000	2,670	3,180	4,680
3,200	2,670	2,670	4,440
3,400	2,670	2,670	4,210
3,600	2,670	2,670	4,000
3,800	2,670	2,670	3,790
4,000	2,670	2,670	3,600
4,200	2,670	2,670	3,410
4,400	2,670	2,670	3,240
4,600	2,670	2,670	2,670
4,800	2,670	2,670	2,670
5,000	2,670	2,670	2,670
5,200	2,670	2,670	2,670
5,400	2,670	2,670	2,670

* Depends on battery size

Load width B = 1200 mm Safety clearance: 400 mm			
Aisle A ₁ mm*	Main aisle A ₂ mm*		
	Load length L		
	4 m	6 m	8 m
3,200	3,050	3,550	5,070
3,400	3,050	3,050	4,820
3,600	3,050	3,050	4,590
3,800	3,050	3,050	4,370
4,000	3,050	3,050	4,160
4,200	3,050	3,050	3,960
4,400	3,050	3,050	3,770
4,600	3,050	3,050	3,590
4,800	3,050	3,050	3,050
5,000	3,050	3,050	3,050
5,200	3,050	3,050	3,050
5,400	3,050	3,050	3,050

* Depends on battery size

Load width B = 1200 mm Safety clearance: 400 mm			
Aisle A ₁ mm*	Main aisle A ₂ mm*		
	Load length L		
	4 m	6 m	8 m
3,200	3,070	3,550	5,070
3,400	3,070	3,070	4,820
3,600	3,070	3,070	4,590
3,800	3,070	3,070	4,370
4,000	3,070	3,070	4,160
4,200	3,070	3,070	3,960
4,400	3,070	3,070	3,770
4,600	3,070	3,070	3,590
4,800	3,070	3,070	3,070
5,000	3,070	3,070	3,070
5,200	3,070	3,070	3,070
5,400	3,070	3,070	3,070

* Depends on battery size

FM-4W 4-Way Reach Truck

Detailed Photos



Adjustable driver's cab with numerous storage compartments



Ergonomic joystick for precise operation



Comfortable tilt seat optimises upward visibility

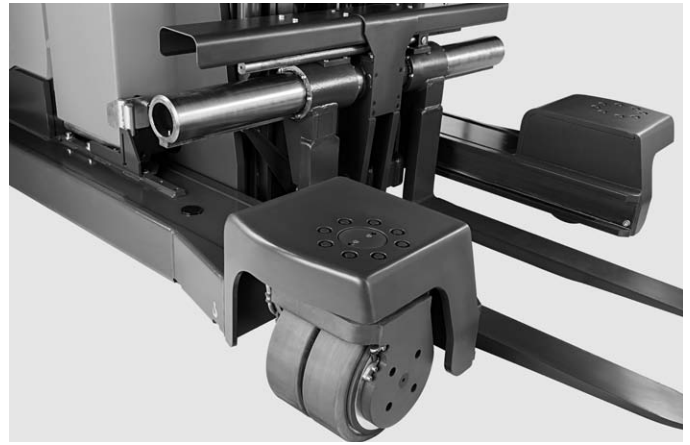

Load wheel can be smoothly put in position for precise sideways travel

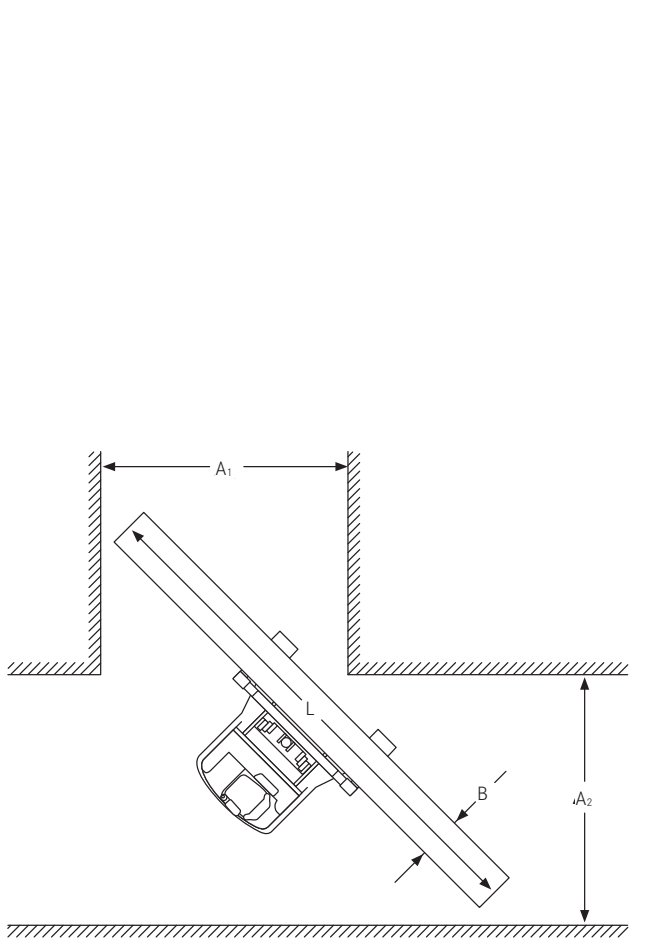

Aisle widths



Optimised view through overhead guard



Hydraulic fork-spreading system ensures safe load handling

FM-4W 4-Way Reach Truck

Fully functional in all directions

Optimised view in all situations

Holistic ergonomics concept

Extensive standard equipment



The FM-4W is a powerful and energy-efficient four-way reach truck. It transports loads forwards, backwards and sideways. This makes this universal truck particularly well suited for transporting long items (in addition to normal pallets and containers). The smart four-way design also allows for a highly cost-effective use of warehouse space because the reach truck can itself be safely and quickly manoeuvred down even the narrowest of aisles. And it always puts in a good shift too: the FM-4W can lift loads with a total weight of 2,500 kg and its high residual load capacity means that it can carry loads weighing as much as 1,000 kg to a height of 9.5 m.

The integrated weight and height display and the comfortable tilt seat greatly facilitate load handling, while the mast and overhead guard are designed to optimise the driver's view of the transported load. Other benefits that make work easier are the lift height pre-selection system and the lift height assistance system. The optional systems noticeably facilitate the quick and precise depositing and retrieval of goods. The seat, arm rests, steering wheel and foot plate can be adjusted to enhance ease of use. A wide range of settings allow the cabin to be adjusted to suit any driver, ensuring optimised ergonomics.

Extensive Equipment

Power

- Stable mast with high residual load capacity for lift heights of up to 9.5 metres (1,000 kg)
- Powerful acceleration combined with high driving speed (up to 13 km/h)
- Sufficient energy for all applications thanks to battery capacities of 465–930 Ah

Precision

- The mast and overhead guard are designed to optimise visibility of the goods
- The wheels can be instantly turned 90° for precise sideways travel
- The hydraulics are closely controlled by proportional valve technology
- Integrated weight and height display for precise load handling
- Excellent handling performance: easier loading and unloading thanks to height assistance system

Ergonomics

- Can be ergonomically adjusted to suit any driver: adjustable seat, arm rests, steering wheel and foot plate
- All functions can be easily operated using the joystick or fingertip control system, without having to keep changing hands

- Comfortable and practical: the seat can be adjusted to suit the driver's weight and has a narrow backrest to ensure good visibility out the back
- The comfortable tilt seat with its pneumatic lumbar support makes it easy to look up and past the goods (maximum tilt: 18°)

Compactness

- Suitable for use in even the narrowest of aisles thanks to the reach truck concept
- Four-way design allows for long items to be transported down the narrowest of aisles

Safety

- The large step and handle make it safe and easy to get in
- Load and truck protection: the assistance system stops forks from coming into contact with the forklift truck's wheel arms
- Work safety: precise movement control
- A high level of driver safety is ensured by load-dependent speed limits and Curve Speed Control

Environmental Responsibility

- Energy is recovered during the braking process to prolong the use of the truck and optimise its use of resources
- Energy savings: the steering electronics are activated only when the steering wheel is moved

FM-4W 4-Way Reach Truck

Equipment Variants



		FM-4W 20	FM-4W 25
Driver's cab	Driver's seat with lengthwise adjustment	●	●
	Comfortable seat with hydraulic shock absorber	●	●
	Tilt seat, tilt angle: 18°	●	●
	Height-adjustable head rest	○	○
	Driver's seat with heating system	○	○
	Driver's seat with leatherette cover	○	○
	Electrically adjustable floor level	●	●
	Display showing active operating statuses and service information	●	●
	Custom programming of driver profiles	●	●
	Rear mirror for sideways travel	○	○
	Panoramic mirror	●	●
	Free view mast with panoramic overhead guard	●	●
Steering	Fully electric 360° steering	●	●
	Length-adjustable control unit	●	●
	Midi steering wheel, height- and tilt-adjustable	●	●
	Mini steering wheel with armrest with height and length adjustment	○	○
Mast	Triplex free view mast with free lift	●	●
	Mast reach damping system	●	●
	Cushioned lift stop	●	●
	Mast tilt: 1.5° forwards / 3.5° backwards (depending on mast)	○	○
Fork carriage	Manual prong adjustment, adjustment range 560-1,550 mm	○	○
	Manual prong adjustment, adjustment range 560-2,220 mm	○	○
	Hydraulic prong adjustment, adjustment range 560-1,550 mm	●	●
	Hydraulic prong adjustment, adjustment range 560-2,220 mm	○	○
Hydraulics	Reduced speed when fork carriage is raised	○	○
	Operated by four individual levers	○	○
	Operated by joystick	●	●
	Noise-optimised hydraulic pump	●	●
	Extra hydraulics	○	○
	Proportional valve technology for high-precision movements	●	●
Drive	Custom parametrisation of hydraulic functions	●	●
	Rotary current drive	●	●
	Drive wheel made of Vulcollan®	●	●
Brake	Drive wheel made of Tractothan®	○	○
	Electromagnetic disc brake used as operating brake and parking brake	●	●
	Electric load roller brake	●	●
Safety and performance	Regenerative braking system / energy recovery during braking process	●	●
	Key switch	●	●
	Access authorisation based on PIN code or card	○	○
	Mesh grid on overhead guard	○	○
	Mast automatically moves into upright position at the touch of a button	○	○
	Fork protection zone	○	○
	Crash sensor	○	○
	Traction control	○	○
	Weight measurement ± 50 kg	●	●
	Warning light	○	○
	Front headlights	○	○
	Lift stop function	○	○
Battery system	Lift height display	●	●
	Lift height pre-selection system	○	○
	Height assistance system	○	○
	Service intervals shown in display	○	○
	Roller track for lateral battery change	○	○
	Electric battery replacement system (only available with battery tray F, 775 Ah)	—	○
	Acoustic battery discharge warning	○	○
	Battery tray C for 465 Ah battery	○	—
Battery tray E for 620 Ah battery	●	○	
Additional equipment	Battery tray F for 775 Ah battery	○	●
	Battery tray G for 930 Ah battery	○	○
	Time-controlled deactivation of electrical system after leaving the forklift truck	○	○
	Cabin with heating (only available with battery tray F, 775 Ah, and G, 930 Ah)	○	○
	Intercom system	○	○
	Window opening in cabin door	○	○
	Moisture proofing	○	○
	Writing desk	○	○
Accessory holder	○	○	
	12 V socket	○	○
	Rear-view camera	○	○
	CD/MP3 radio	○	○

● Standard ○ Option — Not available

STILL



STILL Materials Handling Ltd
Aston Way
Leyland Preston
PR26 7UX
Tel.: +44 (0)845 603 6827
Fax: +44 (0)1772 454668

STILL Materials Handling Ltd
19 Hennock Road
Marsh Barton Trading Estate
Exeter
EX2 8RU
Tel.: +44 (0)1392 435151
Fax: +44 (0)1392 824328
info@still.co.uk

For further information please visit:
www.still.co.uk



STILL is certified in the following areas: Quality management, occupational safety, environmental protection and energy management.



first in intralogistics