

R 07/R 08 Technical Data Electric Tractors/Platform Trucks

R 07-25

R 07-25 L

R 08-20



In accordance with VDI guidelines 2198, this specification applies to the standard model only. Alternative tyres, mast types, ancillary equipment, etc. could result in different values.

Characteristics	1.1	Manufacturer			STILL	STILL	STILL
	1.2	Manufacturer's model designation			R 07-25	R 07-25 L	R 08-20
	1.3	Drive			Electric	Electric	Electric
	1.4	Operation			Rider seated	Rider seated	Rider seated
	1.5	Carrying capacity/load	Q	kg	300	300	2000
	1.5.1	Trailer load	Q	kg	25000	25000	See diagram
	1.7	Towing capacity	F	N	5000	5000	900
Weight	1.9	Wheel base	y	mm	1465	1900	1900
	2.1	Service weight incl. battery		kg	3800	4800	3100 3200
	2.2	Axle loadings laden, front		kg	2000	2600	2300 2100
	2.2.1	Axle loadings laden, rear		kg	2100	2500	2800 3100
	2.3	Axle loadings unladen, front		kg	1900	2500	1800 1800
2.3.1	Axle loadings unladen, rear		kg	1900	2300	1300 1400	
Wheels Tyres	3.1	Tyres			Pneumatic/superelastic	Pneumatic/superelastic	Pneumatic/superelastic
	3.2	Tyre size, front			6.00 R 9	6.00 R 9	6.00 R 9
	3.3	Tyre size, rear			7.00 R 12	7.00 R 12	7.00 R 12
	3.5	Number of wheels, front (x = driven wheel)			2	2	2
	3.5.1	Number of wheels, rear (x = driven wheel)			2x	2x	2x
	3.6	Track width, front	b ₁₀	mm	1102/1112	1102/1112	1102/1112
	3.7	Track width, rear	b ₁₁	mm	1018	1018	1018
Dimensions	4.7	Height to top of overhead guard (cabin)	h ₆	mm	1820	1820	1820
	4.8	Seat height	h ₇	mm	745	745	745
	4.12	Coupling height	h ₁₀	mm	240, 295, 350, 405	240, 295, 350, 405	240, 295, 350, 405
	4.13	Platform height unladen	h ₁₁	mm	1000	1000	840
	4.16	Platform length	l ₃	mm	1520	1955	2200 2600
	4.17	Rear overhang	l ₅	mm	615	615	730 1130
	4.18	Platform width	b ₉	mm	1170	1170	1300
	4.19	Overall length	l ₁	mm	3045	3480	3590 3990
	4.21	Overall width	b ₁	mm	1300	1300	1300
	4.32	Ground clearance at centre of wheel base	m ₂	mm	150	150	150
Performance	4.35	Outer turning radius	W _a	mm	2825	3275	3275
	4.36	Inner turning radius	b ₁₃	mm	935	1095	1095
	5.1	Speed laden		km/h	11	11	15
	5.1.1	Speed unladen		km/h	25	25	20
	5.5	Rated drawbar pull, laden		N	-	-	-
	5.5.1	Rated drawbar pull, unladen		N	5000	5000	900
	5.6	Max. drawbar pull, laden		N	-	-	-
	5.6.1	Max. drawbar pull, unladen		N	16000	16000	3500
	5.7	Gradeability, laden		%	see performance diagram	see performance diagram	see performance diagram
	5.7.1	Gradeability, unladen		%			
5.8	Max. gradeability, laden		%				
5.8.1	Max. gradeability, unladen		%				
5.10	Brakes			Electric/hydraulic	Electric/hydraulic	Electric/hydraulic	
Motors	6.1	Drive motor hourly capacity		kW	20	20	5
	6.3	Battery equipment to DIN 43531/35/36 A, B, C, no			43536 A	43536 A	43536 A
	6.4	Battery voltage	U	V	80	80	80
	6.4.1	Battery capacity	K ₅	Ah	460 560	700 840	240 320
	6.5	Battery weight		kg	1210 1558	1863 2178	679 858
Other	8.1	Drive control			AC-microprocessor	AC-microprocessor	AC-microprocessor
	8.4	Average noise peak at operator's ears		dB(A)	69	69	69
	8.5	Trailer coupling, type/DIN			Rockinger 244	Rockinger 244	Rockinger 244

Dimensional sketch and operating data

When hauling loaded trailers that are coupled to platform or towing trucks under the most arduous of operating conditions (e. g. sloping surfaces, smooth or slippery roadways, etc.) the determining factor for trailing load assessment will not be the tractive effort developed by the towing truck, nor the carrying capacity of the relevant trailers, but rather the presence of an effective brake system eliminating the risk of accidents (i.e. by using trailers equipped with brakes of the overrun type).

When towing trailer trains on public roads, the Road Traffic Regulations must be adhered to. The values contained in this specification and data sheet, including the performance charts, apply to tractors operating on a dry concrete surface.
Rolling resistance on level surface: 200 N/t.
Frictional coefficient for tyres: 0.80;
Height of towing bracket: 400 mm.
Tipping limit: the static load on the steered wheels is 20% below the net weight of the tractor.

Electric Tow Tractor R 07-25

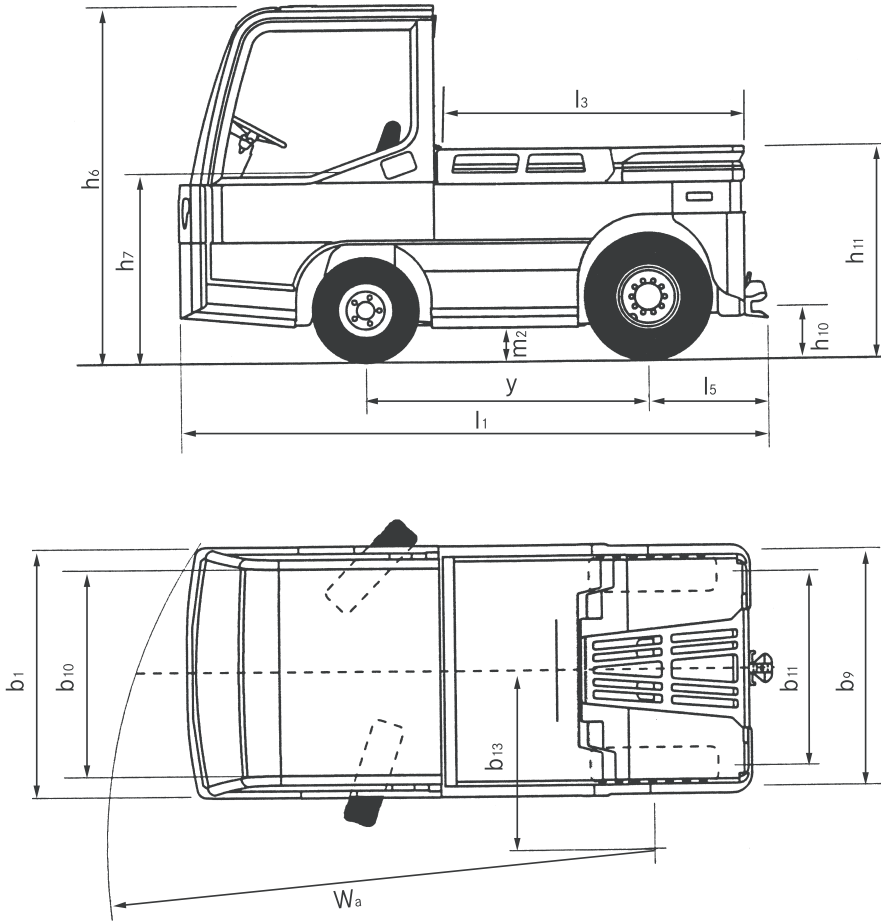

Electric Platform Truck R 08-20

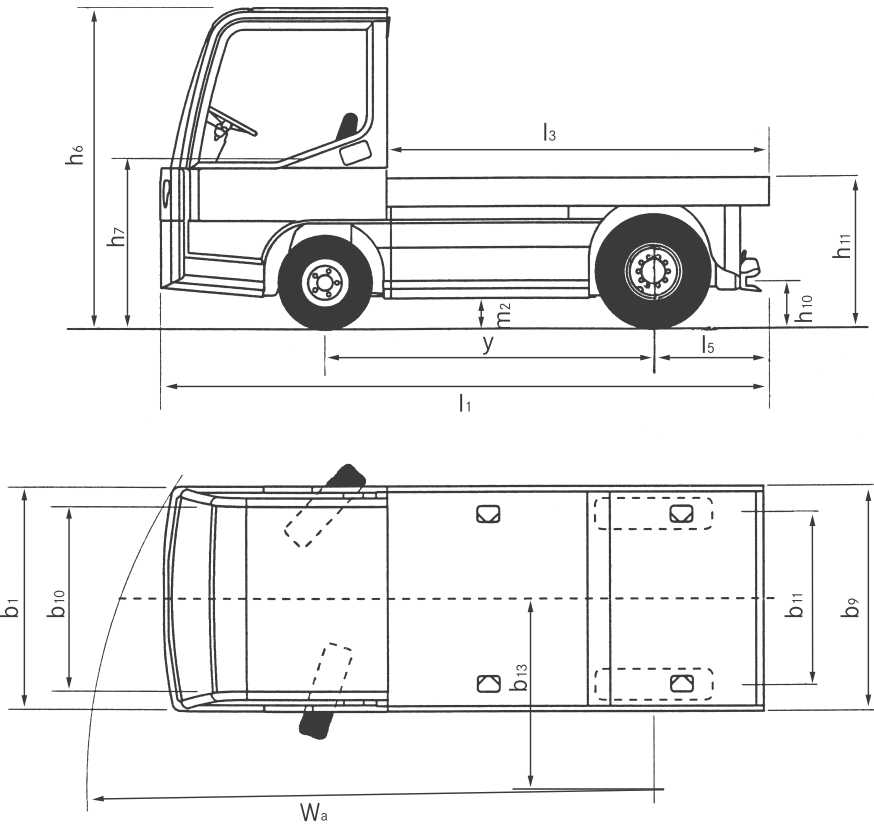

The models depicted in this brochure may contain special parts or attachments which are not supplied as standard.

Performance Diagram R 07-25

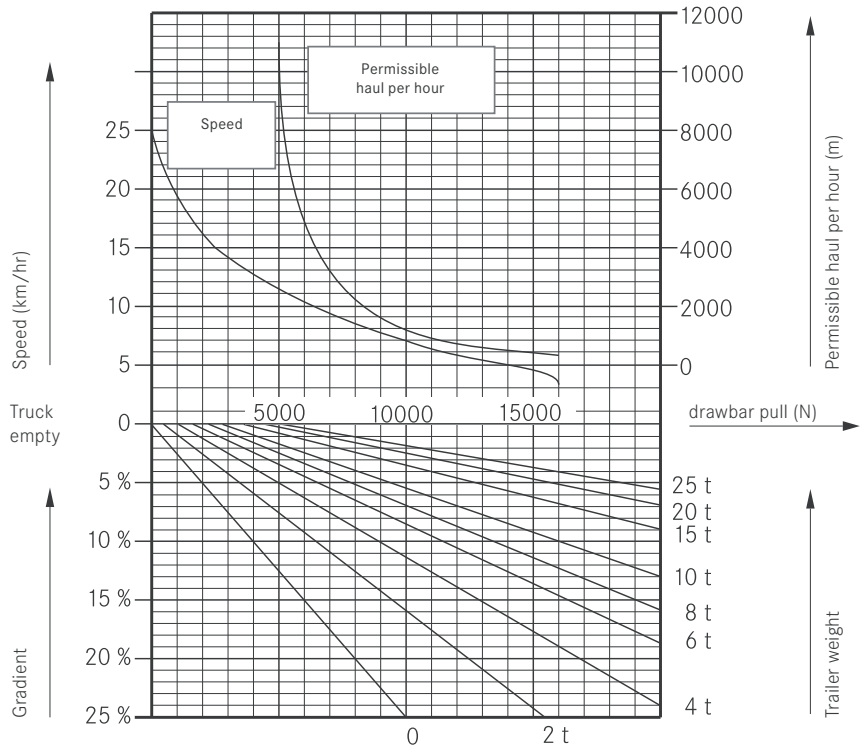

The Speed/Draw Bar Pull performance of the tractor can be programmed between the two limits shown to suit the application. The permissible haul per hour is the total distance travelled, including the return journey and any downhill gradients. It is recommended that braked trailers are used for trailer loads exceeding 9 tonnes and for all trailer loads if gradients are involved.

Performance Diagram R 08-20

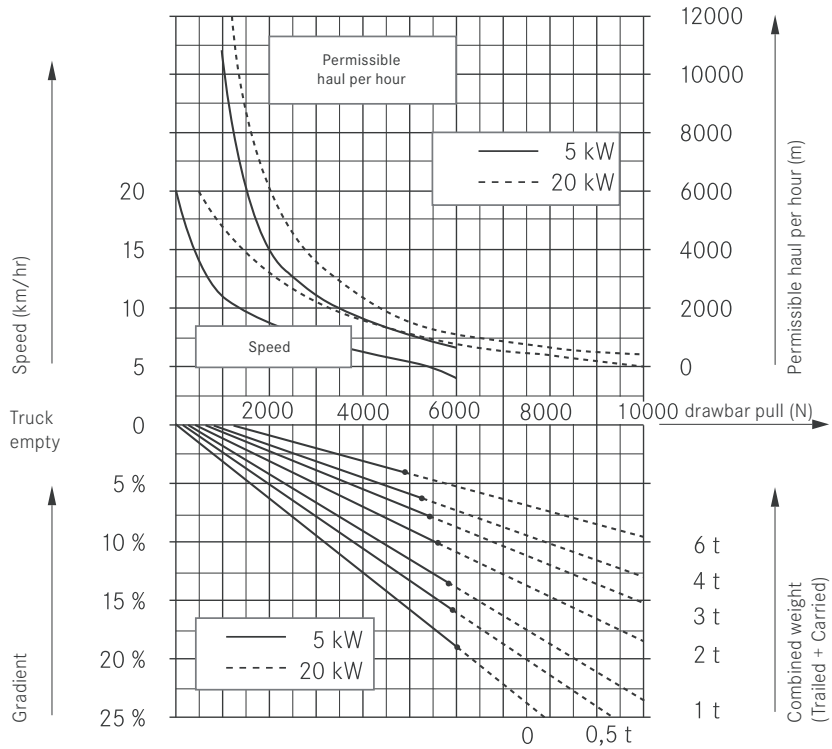

The permissible haul per hour is the total distance travelled, including the return journey and any downhill gradients. It is recommended that braked trailers are used for all trailer loads if gradients are involved.

Drive

- The encapsulated 80 volt three-phase drive motor from STILL gives long life and freedom from maintenance, with optimal energy utilisation.
- During braking the drive motor acts as a generator and feeds electrical energy back into the battery. This allows a longer period of work before the battery needs recharging.
- Due to the regulated drive control, the travel speed will remain constant for the same pedal position regardless of upward or downward gradients.

Battery and battery changing

Battery changing is by means of a hoist. On the R 08-20 the battery can also be removed from the side with a low lift pallet truck.

Electrical system

The trucks are fitted with an energy saving MOSFET controller. Drive and steering unit are linked through a CAN bus to the combi instrument. Constant checks guarantee fault-free operation.

Brakes

- The truck has three independent braking systems.
- Disc brakes at the front and maintenance free multi-disc brakes in an oil bath at the back are actuated hydraulically with the brake pedal.
- A mechanical handbrake acts on the rear wheels.

Steering

- The servo-steering is extremely free moving and allows fatigue-free driving.
- The sturdy steering axle gives the truck very good manoeuvrability and makes it extremely manageable.

Frame

The flat, shock resistant chassis is specified and designed in accordance with FEM. Due to its robust steel structure it has very high resistance to distortion and high rigidity. The design prevents the accumulation of water at any point in the frame. This corrosion protection guarantees a long life.

Lighting

- Road Traffic Act lighting system fitted as standard.
- Rear lights can be fitted at the top of the overhead guard as an option.
- Optimum rear visibility thanks to the large viewing channel of the R 07-25.

Driver's compartment

- Automotive style foot pedal layout.
- Seat and steering column are adjustable.
- On the R 07-25 the driver has a clear view onto the tow coupling from the driving compartment.
- Convenient entry and exit and also a relaxed leg position due to the low step height, large footwell and anti-slip liner.
- Excellent all-round visibility.

Standard equipment

- Sprung driver's seat, PVC.
- Passenger's seat, PVC.
- Pneumatic tyres.
- Work hour meter through key switch and seat switch.
- Paint RAL 2000/RAL 7021.
- Forward/reverse inching button device on the R 07-25.
- Automatic coupling, rear.
- Trailer socket

Auxiliary equipment

- Tow coupling, front (1 x automatic or three position coupling).
- Tow coupling, rear (2 x automatic coupling, three position or automatic remote coupling).
- Cloth covered seat (with or without seat heater).
- SE tyres.
- Power supply can be extended with a 12 volt converter for auxiliary electrics.
- The R 08-20 can be customised for use in any industry by fitting additional equipment.
- Cab for the R 07-25 also available with sliding doors.

STILL



STILL Materials Handling Ltd
Aston Way
Leyland Preston
PR26 7UX
Tel.: +44 (0)845 603 6827
Fax: +44 (0)1772 454668

STILL Materials Handling Ltd
19 Hennock Road
Marsh Barton Trading Estate
Exeter
EX2 8RU
Tel.: +44 (0)1392 435151
Fax: +44 (0)1392 824328
info@still.co.uk
For further information please visit:
www.still.co.uk



STILL is certified in the following areas: Quality management, occupational safety, environmental protection and energy management.



first in intralogistics