



**STRONG PARTNERS.
TOUGH TRUCKS.™**



REACHSTACKER CONTAINER HANDLERS

**RS 45-27 CH, RS 45-31 CH, RS 46-36 CH
RS 46-41L CH, RS 46-41S CH, RS 46-41LS CH**

REACHSTACKER INTERMODAL HANDLERS

**RS 45-24 IH, RS 45-28 IH, RS 46-33 IH
RS 46-38L IH, RS 46-38S IH, RS 46-38LS IH**



POWERTRAINS

DESIGNATION		HYSTER	HYSTER
1.1	Manufacturer (abbreviation)	HYSTER	HYSTER
1.2	Manufacturer's type designation	RS CH	RS IH
1.3	Drive: electric (battery or mains), diesel, petrol, fuel gas	Diesel	Diesel
POWER UNIT			
7.1	Engine manufacturer / type Stage IV	Cummins QSL9	Cummins QSL9
7.2	Engine power according to ISO 1585 Stage IV	261 @ 2100	261 @ 2100
7.2.1	Max. engine power according to ISO 1585 Stage IV	283 @ 1900	283 @ 1900
7.3	Rated speed	2,100	2,100
7.3.1	Torque at 1/min Stage IV	1627 @ 1500	1627 @ 1500
7.4	Number of cylinders / displacement Stage IV	6 / 8900	6 / 8900
7.5.1	Fuel consumption according to VDI cycle	On Request	On Request
DRIVE TRAIN			
8.1	Type of drive unit	Torque Converter	Torque Converter
8.2.1	Transmission manufacturer / type	Spicer Off-Highway / TE-32	Spicer Off-Highway / TE-32
8.6	Wheel drive / drive axle manufacturer/type	Kessler / D102PL341/528-NLB	Kessler / D102PL341/528-NLB
8.11	Service brake	Oil immersed disc	Oil immersed disc
8.12	Parking brake	Dry disc on drive axle	Dry disc on drive axle
SPREADER			
9.1	Manufacturer / type	Elme / 817	Elme / 857
9.1.1	Pile slope spreader, mechanical without PPS	3	3
9.1.2	Pile slope spreader, mechanical with PPS	1.5	1.5
9.1.3	Pile slope spreader, Power Pile Slope	6	6
9.3	Size of containers	ISO 20' - 40'	ISO 20' - 40'
9.4	Side thrust	800 / 800	800 / 800
9.6.1	Rotation angle, without override	+12 / -12	+12 / -12
9.6.2	Rotation angle, with override	+185 / -95	+185 / -95

TRUCK DIMENSIONS

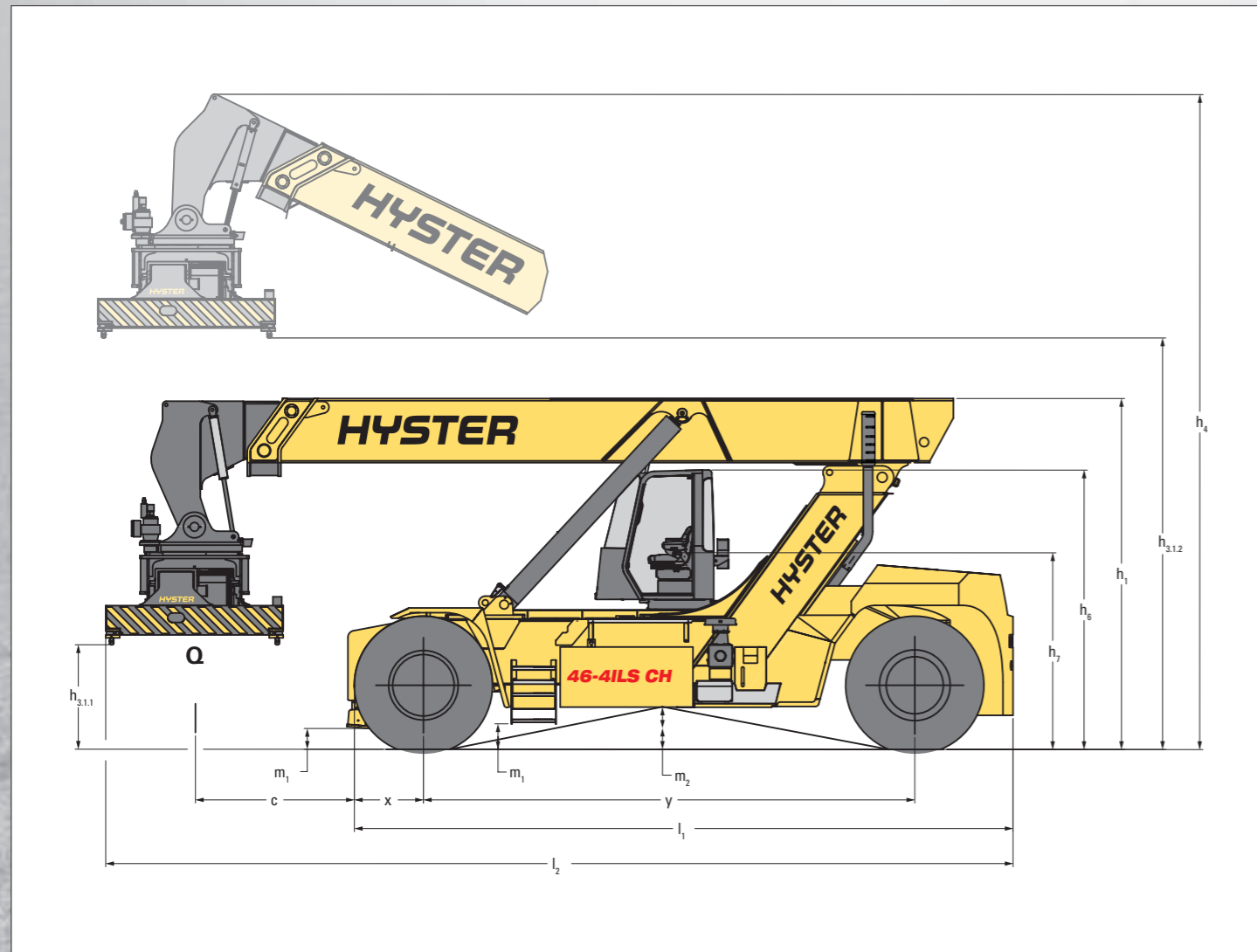

TRUCK DIMENSIONS

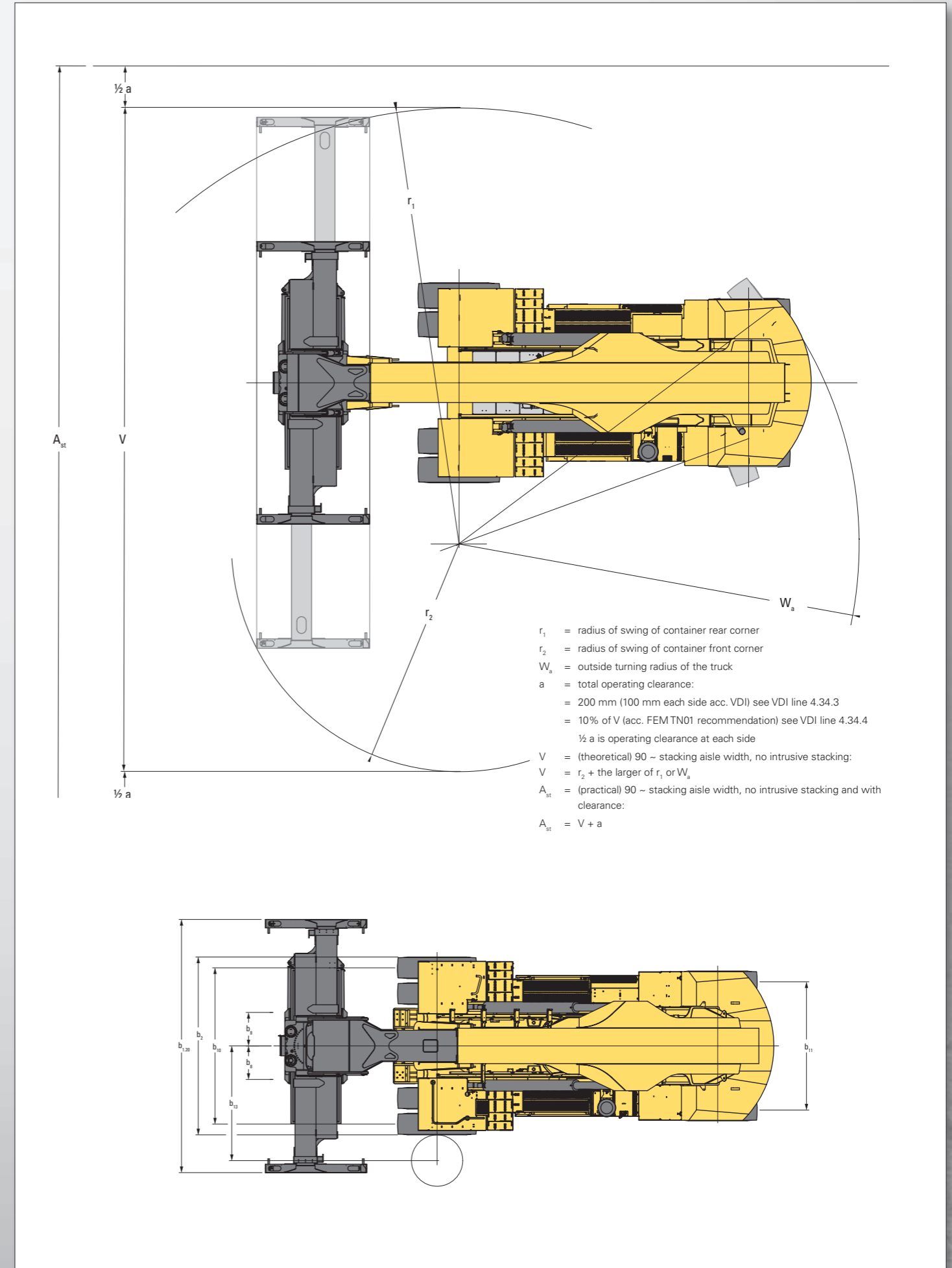

RATED CAPACITIES AND STACKING HEIGHTS – CONTAINER HANDLERS

RS 45-27 CH CONTAINER SPREADER

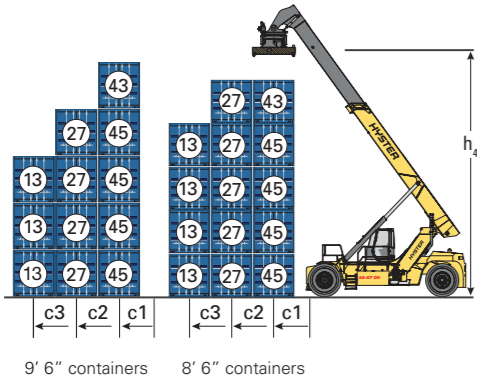

RS 46-41L CH CONTAINER SPREADER

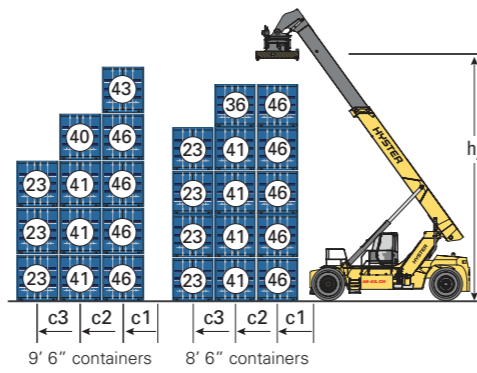

RS 45-31 CH CONTAINER SPREADER

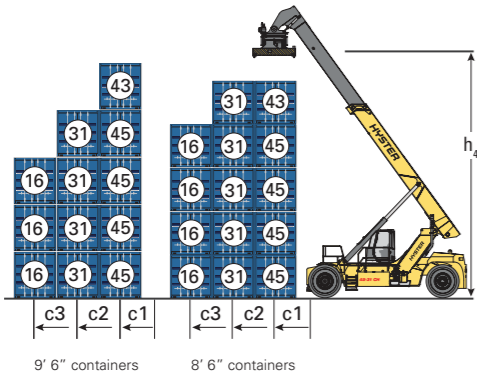

RS 46-41S CH CONTAINER SPREADER

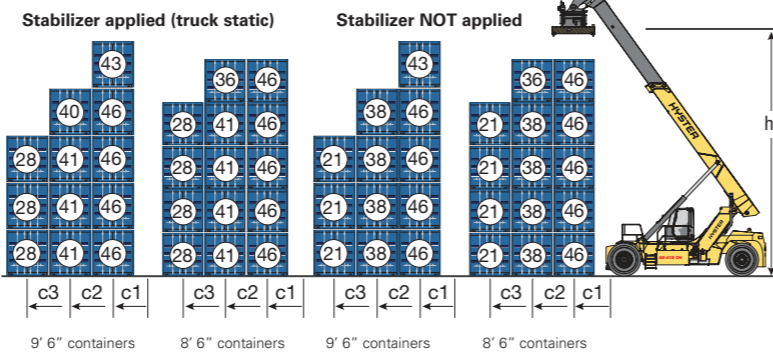

Note: All load centres c1, c2, c3 are taken from the front face of the (front) tyres, deduct 100mm for load centres taken from the front face of the Stabilizer.

RS 46-36 CH CONTAINER SPREADER

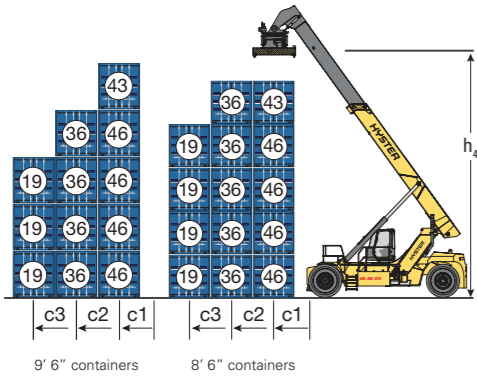

RS 46-41LS CH CONTAINER SPREADER

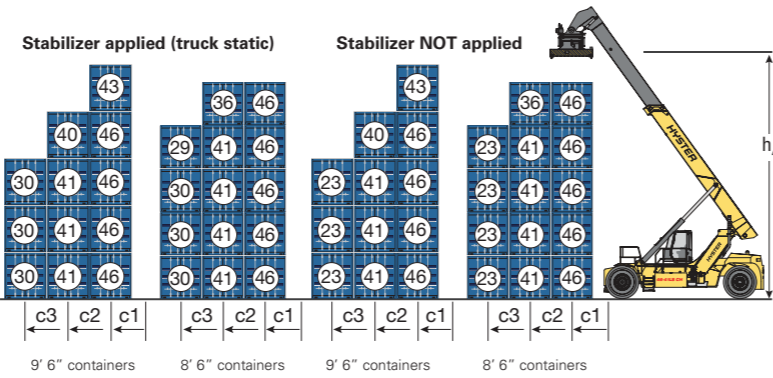

Note: All load centres c1, c2, c3 are taken from the front face of the (front) tyres, deduct 100mm for load centres taken from the front face of the Stabilizer.

NOTE: Care must be exercised when handling elevated loads. When the load is elevated, truck stability is reduced.

RATED CAPACITIES AND STACKING HEIGHTS – INTERMODAL HANDLERS

RS 45-24 IH INTERMODAL SPREADER

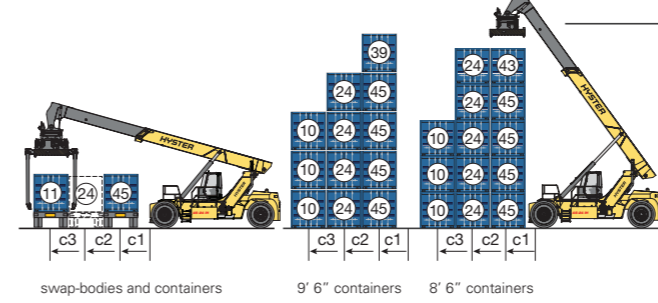

RS 46-38S IH INTERMODAL SPREADER

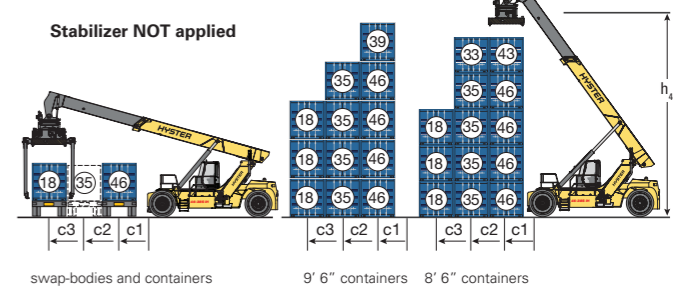

RS 45-28 IH INTERMODAL SPREADER

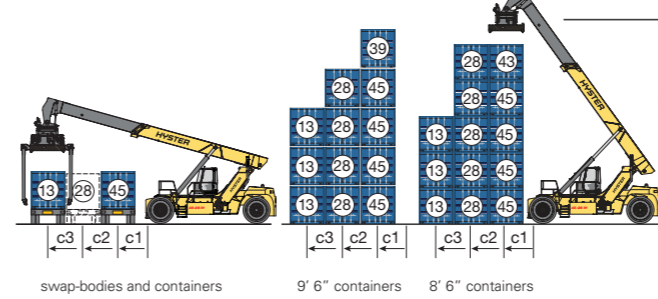

Stabilizer applied (truck static)

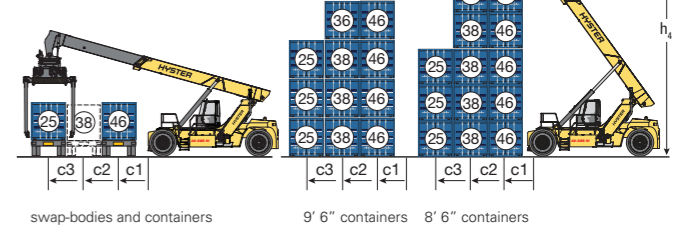

Note: All load centres c1, c2, c3 are taken from the front face of the (front) tyres, deduct 100mm for load centres taken from the front face of the Stabilizer.

RS 46-33 IH INTERMODAL SPREADER

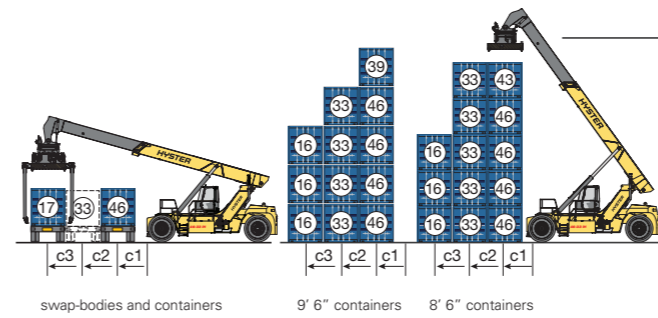

RS 46-38LS IH INTERMODAL SPREADER

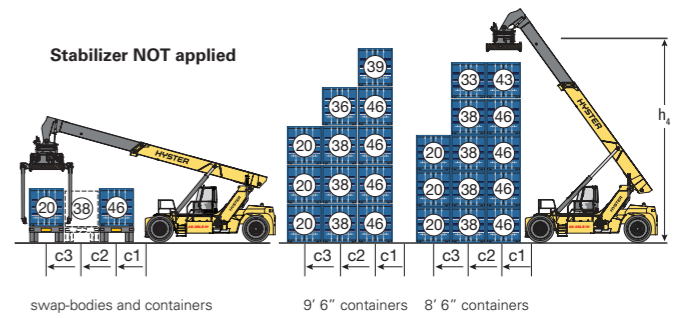

RS 46-38L IH INTERMODAL SPREADER

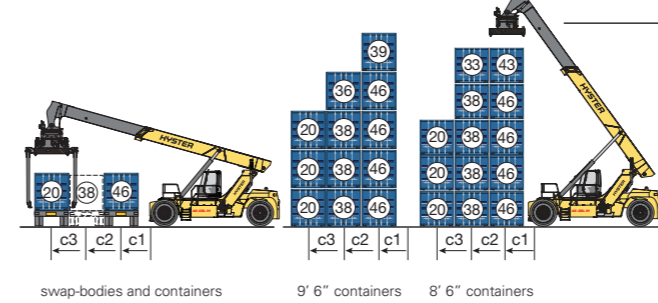

Stabilizer applied (truck static)

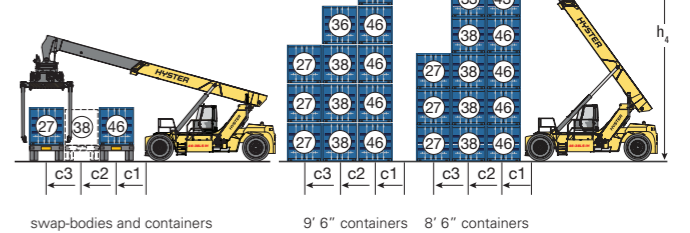

Note: All load centres c1, c2, c3 are taken from the front face of the (front) tyres, deduct 100mm for load centres taken from the front face of the Stabilizer.

NOTE: Care must be exercised when handling elevated loads. When the load is elevated, truck stability is reduced.

> FRONT END EQUIPMENT

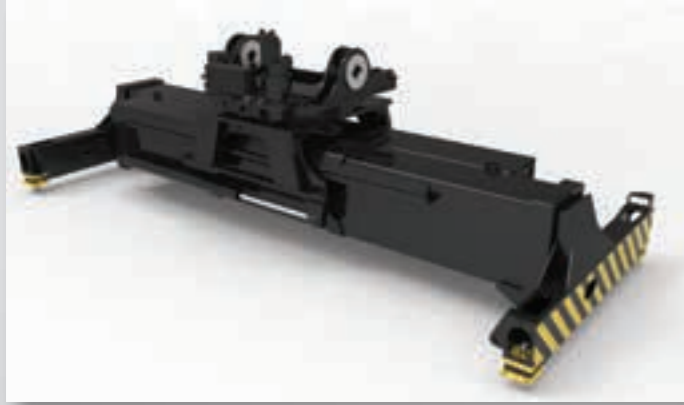

20'-40' telescopic ISO top pick spreader with mechanical pile slope



20'-40' telescopic ISO top pick spreader with powered pile slope



20'-40' telescopic spreader with powered pile slope and foldable 'Piggy back' legs in



20'-40' telescopic spreader with powered pile slope and foldable 'Piggy back' legs out

> STANDARD AND OPTIONAL EQUIPMENT

STANDARD EQUIPMENT:

- Cummins QSL 9L 261 / max. 283 KW @ 1.900 rpm Turbo Diesel Engine
 - Stage IV Compliant
 - ECO-eLo / HiP performance modes
 - Hibernate Idle
 - Hydraulically driven cooling fan
- DANA Spicer Off-Highway TE-32 4 Speed Auto-shifting transmission
- Automatic 'rev-up' function when lifting:
 - If not in gear or when the inching pedal is depressed, the engine automatically revs up, (up to 1800 rpm) when lifting
 - When in gear, the 'auto-rev-up' function is disengaged
- 2 Stage Boom
- Integrated CH Spreader, ELME Model 817 with Mechanical Pile Slope

- Integrated IH Spreader, ELME Model 857 with Powered Pile Slope and Powered dampening for Intermodal Handlers
- Wet Disc Brakes
- Kessler D102 PL 341/528 NLB Drive Axle
- Steer Axle with Tyre Life Enhancement System
- Power-on-Demand Load Sensing Hydraulic System featuring Variable Displacement Pump Technology
- Directional Control Lever
- Tyres – Drive and Steer
 - 18.00 – 25 40PR Standard pneumatic
 - 18.00 – 33 36PR Standard pneumatic
- Steer Wheel Nut Protection
- Vista cab featuring:
 - Seat-Side, Joystick Hydraulic Control
 - Multifunctional Display Panel
 - Telescoping & Tilting Steering Column
 - 900 mm sliding cab
 - Floor Mat

- Isolated Mounting for Low Noise and Vibration
- Handrails for Operator Entry and Exit (Left Side)
- Steering Wheel Spinner Knob
- Air Compressor Horn
- Heater with 3 speed fan
- Front and rear window defrosters
- H-type double Front screen wiper
- Top and Rear Wipers
- Recirculation Fan
- 3B6 Load Moment Indicator with Monochrome Display
- 3B6 Load Moment Indicator with colour Display for 'S' models
- Mechanical, Full Suspension Cloth Seat with integrated adjustable armrest, high backrest, head rest and seat belt
- Electronic Twist Lock Position Indicator with L.E.D. Signals and Audible Tone (TWIST Module)

- Interior Wide Angle Mirrors
- External Wide Angle Mirrors Mounted on Front Fenders
- Operator Presence System
- Lockable Battery Disconnect Switch
- 24 V Electrical System
- 120 amp Alternator
- Lifting Eyes to Hoist Complete Truck
- Light Kit 1, consisting of:
 - Front: 4 Halogen Work Lights, Fender Mounted
 - 2 Marker Lights
 - 4 Halogen Lights Boom Mounted

- Rear: 2 Rear Mounted Halogen Lights
- 2 Stop/Tail/Backup Lights
- Turn Signal & Hazard Lights
- Spreader: 2 Halogen Work Lights on Spreader
- Visible Alarm – Amber Strobe Light – Key switch Activated
- Audible Alarm – Reverse Direction Activated 82–102 dB(A)
 - Self adjusting
- Non-Locking Fuel Cap

- Literature Package
 - Operator's Manual
- Warranty
 - 12 Months / 2,000 Hours Manufacturer's Warranty

OPTIONAL EQUIPMENT:

- DANA Spicer Off-Highway TE-27 4 Speed Auto-shifting transmission
- Engine pre-heater 230 V (AC)
- NATO plug Start aid
- 24V heated diesel filter
- Spreader Options:
 - Powered Pile Slope on CH
 - Powered Dampening on CH
 - 4 Lifting Eyes Located Under Center Beam of Spreader
- Tire Options – Drive and Steer:
 - 18.00 – 25 40PR STMS slick
 - 18.00 – R25 Radial slick
 - 18.00 – R33 Radial slick
- Vista cab options:
 - Air conditioning with sun shades on top and rear
 - Temperature controlled air conditioning with sun shades on top and rear
 - High performance temperature controlled air conditioning with sun shades on top and rear
 - 2.600 mm sliding cab with extra cab access exit in the fully forward position on CH
 - Sun rollo on top and rear windows
 - Trainers seat
 - IT equipment bar
 - Rear locking console
 - Heated top window
 - Audio system set-up (wiring, two speakers and antenna)
 - Front screen with single wiper
 - Right hand side stairway and handrails
 - DC/DC converter 24 Volt/12 Volt with 1 or 2 sockets

- Seat Options:
 - Pneumatic, Full Suspension cloth seat with integrated adjustable armrest, high backrest, head rest and seatbelt
 - Deluxe air suspended seat with adjustable shock absorber forward and backward motion +/- 25 mm, cushion 21°; 150 mm higher backrest, head rest and 3-points high visibility seatbelt
 - Heated Deluxe air suspended seat
- 3B6 Load Moment Indicator with colour display
- Light Kit 2, consisting of:
 - Front: 4 HID Work Lights Fender Mounted
 - 2 Marker Lights
 - 4 Halogen Lights Boom Mounted
 - Rear: 2 Rear Mounted Halogen Lights
 - 2 Stop/Tail/Backup Lights
 - Turn Signal & Hazard Lights
 - Spreader: 1 HID Work Lights on Spreader
- Light Kit 3 with staircase and engine compartment lights, consisting of:
 - Front: 4 Halogen Work Lights Fender Mounted
 - 2 Marker Lights
 - 4 Halogen Lights Boom Mounted
 - Rear: 2 Rear Mounted Halogen Lights
 - 2 Stop/Tail/Backup Lights
 - Turn Signal & Hazard Lights
 - Spreader: 2 Halogen Work Lights on Spreader

- Light Kit 4 with staircase and engine compartment lights, consisting of:
 - Front: 4 HID Work Lights Fender Mounted
 - 2 Marker Lights
 - 4 Halogen Lights Boom Mounted
 - Rear: 2 Rear Mounted Halogen Lights
 - 2 Stop/Tail/Backup Lights
 - Turn Signal & Hazard Lights
 - Spreader: 1 HID Work Lights on Spreader
- Traction Speed Limiter – factory pre-set to 16 km/h or 20 km/h
- Automatic Engine Shutdown
- Auto Greasing System
 - Basic Truck / Outer Boom
 - Spreader / Inner Boom
- Hyster Tracker Wireless Asset Management system

Other options available through Special Products Engineering Development (SPED). Contact Hyster for details.

STRONG PARTNERS. TOUGH TRUCKS.™

FOR DEMANDING OPERATIONS, EVERYWHERE.

Hyster supplies a complete range of warehouse equipment, IC and electric counterbalanced trucks, container handlers and reach stackers. Hyster is committed to being much more than a lift truck supplier.

Our aim is to offer a complete partnership capable of responding to the full spectrum of material handling issues: Whether you need professional consultancy on your fleet management, fully qualified service support, or reliable parts supply, you can depend on Hyster.

Our network of highly trained dealers provides expert, responsive local support. They can offer cost-effective finance packages and introduce effectively managed maintenance programmes to ensure that you get the best possible value. Our business is dealing with your material handling needs so you can focus on the success of your business today and in the future.



HYSTER EUROPE

Centennial House, Frimley Business Park, Frimley, Surrey, GU16 7SG, England.

Tel: +44 (0) 1276 538500



 www.hyster.eu  infoeurope@hyster.com  [/HysterEurope](https://www.facebook.com/HysterEurope)  [@HysterEurope](https://twitter.com/HysterEurope)  [/HysterEurope](https://www.youtube.com/HysterEurope)  www.hyster-bigtrucks.com

HYSTER-YALE UK LIMITED trading as Hyster Europe. Registered Address: Centennial House, Building 4.5, Frimley Business Park, Frimley, Surrey, GU16 7SG, United Kingdom.

Registered in England and Wales. Company Registration Number: 02636775.

HYSTER,  and FORTENS are registered trademarks in the European Union and certain other jurisdictions.

MONOTROL® is a registered trademark, and DURAMATCH and  are trademarks in the United States and in certain other jurisdictions.

Hyster products are subject to change without notice. Lift trucks illustrated may feature optional equipment.