

FU-X/FS-X Technical Data Rider Seated Low Lift Pallet Trucks

FU-X 20

FS-X 33



This specification sheet to VDI Guidelines 2198 gives the technical figures for the standard truck.
Different tyres, other masts, additional equipment etc. could give different figures.

Characteristics	1.1	Manufacturer			STILL	
	1.2	Manufacturer's model designation			FU-X 20	
	1.3	Drive			Electric	
	1.4	Type of control			Rider seated with steering wheel	
	1.5	Capacity/load	Q	kg	2000	
	1.6	Load centre	c	mm	See table	
	1.8	Load distance	x	mm	See table	
	1.9	Wheel base	y	mm	See table	
	Weights	2.1	Weight (without battery)		kg	777 ¹
2.2		Axle loading laden	front/rear	kg	1372/1807 ²	
2.3		Axle loading unladen	front/rear	kg	967/212 ³	
Wheels Chassis	3.1	Tyres			Vulkollan	
	3.2	Tyre size	front	mm	∅ 250 x 80 / 125 x 50	
	3.3	Tyre size	rear	mm	∅ 85 x 80	
	3.5	Wheels, number (x = driven wheel)	front/rear		1x-2/4	
	3.6	Track width	front	b ₁₀	mm	584.5
	3.7	Track width	rear	b ₁₁	mm	390
	Basic dimensions	4.4	Lift		h ₃	mm
4.15		Height lowered		h ₁₃	mm	85
4.19		Overall length unladen		l ₁	mm	See table
4.20		Length incl. fork back		l ₂	mm	938
4.21		Overall width		b ₁	mm	886
4.22		Fork dimensions		s/e/l	mm	52/170/1150
4.25		Overall fork width		b ₅	mm	560
4.32		Floor clearance centre of wheel base		m ₂	mm	153
4.33		Working aisle width for pallet 1000 x 1200 crossways		A _{st3}	mm	2165
4.34	Working aisle width for pallet 800 x 1200 lengthways		A _{st3}	mm	2365 ⁴	
4.35	Turning radius		W _a	mm	See table	
Performance data	5.1	Travel speed	laden/unladen	km/h	9/12	
	5.2	Lift speed	laden/unladen	m/s	0.073/0.127	
	5.3	Lowering speed	laden/unladen	m/s	0.05/0.040	
	5.10	Service brake			Electric	
Electric engine	6.1	Drive motor, rating S2 = 60 min		kW	3	
	6.2	Hoist motor, rating at S3 = 15 %		kW	2.2	
	6.3	Battery to British Standard/DIN 43531/35/36 A, B, C			DIN 43535 B	
	6.4	Battery voltage, rated capacity C		V/Ah	24/360-640	
	6.5	Battery weight (±5%)		kg	312/502	
Misc.	8.1	Drive control			Electronic	
	8.4	Sound		dB(A)	<70	

¹ Details related to the fork length l = 1150 mm

² Incl. driver, with forks raised and battery type 4PzS 360 Ah

³ Incl. driver, with forks lowered and battery type 4PzS 360 Ah

⁴ See table for other fork lengths

l	c	x	y	l ₁	W _a	A _{st3}
1150	600	910	1592	2088	1873	2363
1400	700	1159	1842	2338	2120	2561
1600	800	1359	2042	2538	2318	2759
1800	900	1359	2042	2738	2318	2959
2390	1200	1781	2464	3328	2734	3553

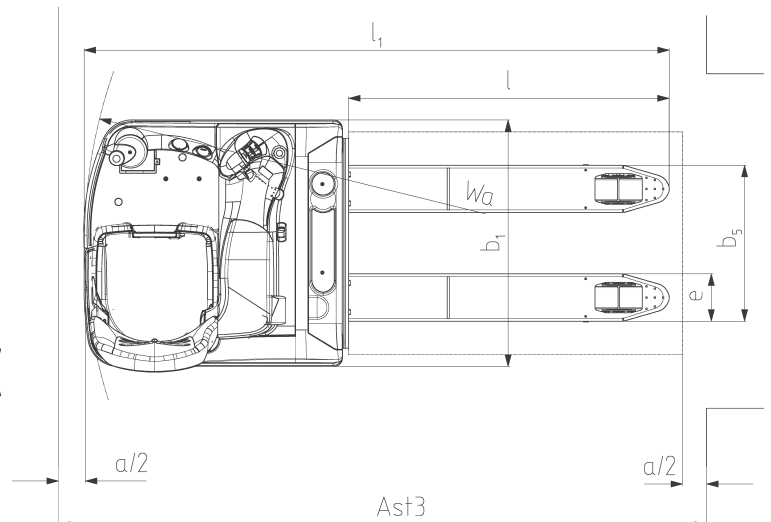
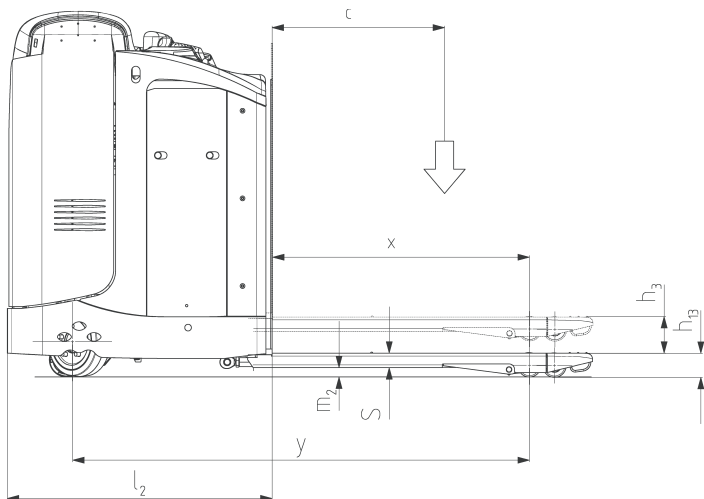

The STILL electric rider seated low lift pallet truck FU-X 20

Designed for high turnaround and efficient horizontal transport of goods up to 2000 kg. An overall width of 880 mm and compact design create conditions for the safe, fast and efficient transport of goods.

Driver's compartment

- Ergonomically laid out driver's compartment with individually adjustable Comfort seat.
- High driver comfort due to padded interior, integral storage compartments for working papers and utensils.
- The non-slip foot plate is damped by a gas spring and its height, which is smoothly adjustable through 120 mm, is adjusted by the driver at the push of a button.
- The ergonomically designed hand grip allows the driver to hold on safely when accelerating and braking.
- The controls are arranged within easy reach without changing the grip and are positively identifiable. The regulation of drive direction and travel speed is through a butterfly switch, the integral function buttons for the lift and lower movements ensure safe working with no chance of confusion.
- Display for battery discharge and work hours as standard.

Chassis

- Very good all round visibility and an optimum view of the fork tips thanks to the new type of rounded chassis contour.
- Robust, torsion free rigid steel frame, consisting of drive and lifting load section.
- A swivel element allows ideal access to the electrical components. Easy access for servicing reduces the maintenance work.
- Safe transport of loads due to automatic level compensation for the load wheels.
- No deformation of the truck frame, constant ground contact even on uneven floors.
- Favourable weight distribution and reduced point loading due to the 4-wheel principle – ideal for end storey work.
- Patented friction aids on the fork tips allow non-slip pallet handling.
- Skids under the fork tips facilitate driving over sills and also entering pallets from the side.

Steering

- Fully electric steering for 180° steering lock with no kick-back. A steering wheel diameter of only 120 mm with 4 1/2 steering turns guarantees quick and effortless steering. Dual safety due to redundant monitoring.
- The steering motor is protected from shocks on uneven surfaces by a safety coupling and connected to the steered wheel by low maintenance direct gearing.
- Automatic speed reduction when travelling round bends, providing high safety due to optimal driving characteristics. This makes it possible to transport loads safely at all times.

Drive unit

- A robust 3.0 kW 3-phase drive motor provides for quick spurts and powerful ramp travel. Best energy utilisation and high efficiency due to spur bevel gearing.

Hydraulics

- The hydraulic unit consists of a powerful 2.2 kW high efficiency pump motor, operated by a push button on the control panel.
- Automatic cut-out on reaching maximum lift provides overload protection for the hydraulic pump – energy saving and noise reducing.

Brakes

- Two independent braking systems.
- Generator braking when the butterfly switch is released or by changing the direction of travel guarantees soft braking. Here the drive unit acts as a generator and feeds the energy recovered back into the battery.
- Electro-magnetic brake as a parking brake or when the emergency off button is operated. It is possible to start on gradients without rolling back.
- Automatic brake monitoring by the ABS function and load-dependent braking regulation.

Battery

- Easy battery changes due to battery free lift and side roller track.
- High safety level due to 2-way locking system.

This specification sheet to VDI Guidelines 2198 gives the technical figures for the standard truck.
Different tyres, other masts, additional equipment etc. could give different figures.

Characteristics	1.1	Manufacturer			STILL	
	1.2	Manufacturer's model designation			FS-X 33	
	1.3	Drive			Electric	
	1.4	Operation			Rider seated	
	1.5	Capacity/load	Q	kg	3300	
	1.6	Load centre	c	mm	1800	
	1.8	Load distance	lowered/raised x	mm	2634/2528	
	1.9	Wheel base	lowered/raised y	mm	3700/3595	
	Weights	2.1	Truck weight (incl. battery)		kg	3560
2.2		Axle loading laden	drive end/load end	kg	3450/3410	
2.3		Axle loading unladen	drive end/load end	kg	2790/770	
Wheels Chassis	3.1	Tyres	drive end/load end		Vulkollan	
	3.2	Tyre size	drive end	mm	∅ 360 x 130	
	3.3	Tyre size	load end	mm	∅ 90 x 95	
	3.5	Wheels, number (x = driven wheel)	drive end/load end		2 x/4	
	3.6	Track width	load end	b ₁₀	mm	370
	3.7	Track width	drive end	b ₁₁	mm	562
	Basic dimensions	4.4	Lift	h ₃	mm	115
4.8		Seat height	h ₇	mm	1474	
4.15		Height lowered	h ₁₃	mm	91	
4.19		Overall length unladen	l ₁	mm	4893	
4.20		Length incl. fork back	l ₂	mm	1305	
4.21		Overall width	b ₁	mm	1000	
4.22		Fork dimensions	s/e/l	mm	70/200/3590	
4.25		Overall fork width	b ₅	mm	570	
4.32		Floor clearance centre of wheel base	m ₂	mm	21	
Performance data	5.1	Travel speed	laden/unladen	km/h	20.0/20.0	
	5.2	Lift speed	laden/unladen	m/s	2.95/2.04	
	5.3	Lowering speed	laden/unladen	m/s	1.60/2.10	
	5.7	Gradeability	laden/unladen	%	8.0/13.0	
	5.10	Service brake			Generator	
	Electric engine	6.1	Drive motor, rating S ₂ = 60 min		kW	2 x 6.5
6.2		Hoist motor, rating at S ₃ = 15 %		kW	2.0	
6.3		Battery to IEC 254-2; A, B, C no			no	
6.4		Battery voltage, rated capacity C _s		V/Ah	48/1000	
6.5		Battery weight ±5% (dependent on make)		kg	1560	
Other	8.1	Drive control			AC current	
	8.2	Working pressure for attachments		bar	140	
	8.4	Noise level, driver's ear		dB(A)	<70	

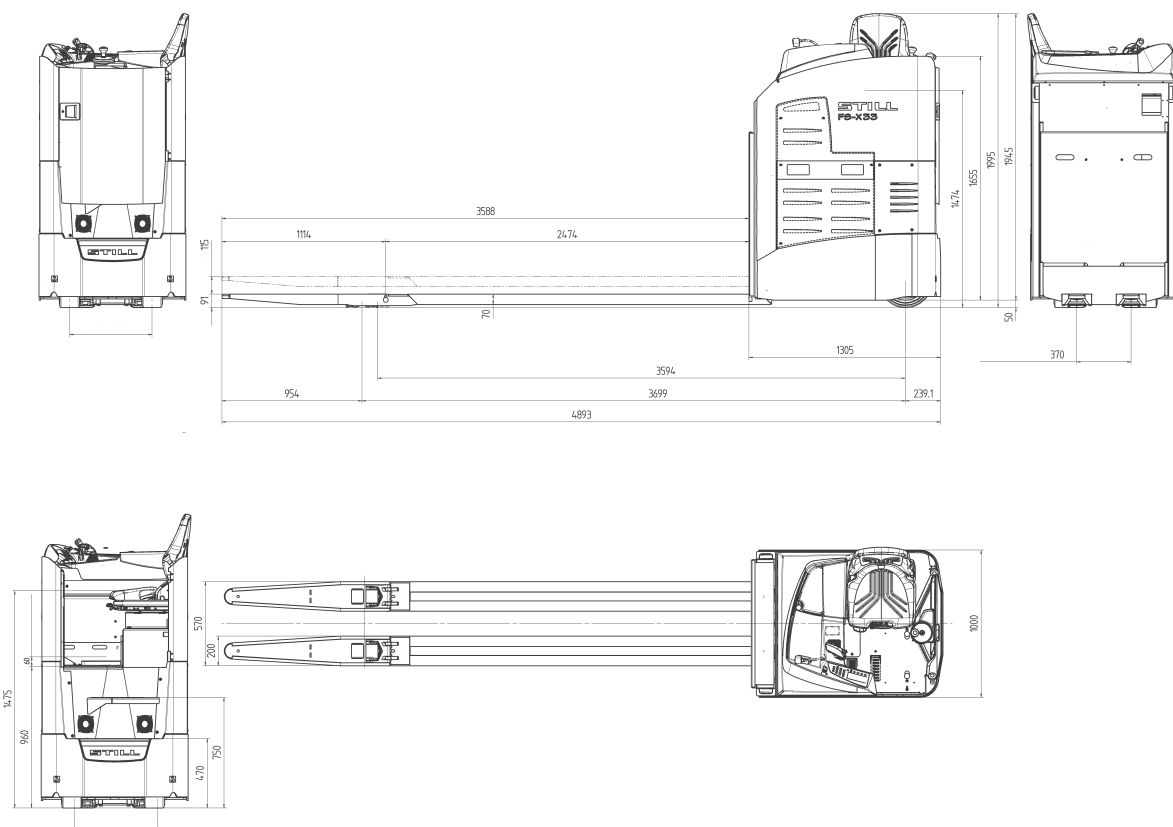

Driver's compartment

- Roomy driver's compartment with adjustable controls and ample legroom.
- Adjustable height platform, individually adjustable to suit different physiques.
- Comfort driver's seat with individual weight and horizontal settings.
- Large area, open steps and hand grips on both sides make entry and exit easy.
- An optional arm rest to the left of the driver's seat provides an relaxed arm position for long runs.
- Individual storage thanks to large utensil compartments and versatile storage options.
- Easily visible LCD display with symbol and numeric displays of all operating states.

Steering

- The steering wheel located on the truck door allows optimal leg clearance. Quick horizontal and vertical setting for all driver physiques, gives the best ergonomics.
- Fully electric 360° steering for light and precise positioning.
- The variable steering ratio makes for smooth straight-ahead running due to an automatic increase in the number of turns when travelling straight ahead and a reduction when shunting.
- Directly geared, redundantly safeguarded steering safety system.
- A constant "9 o'clock position" of the steering wheel means stable, relaxed and safe straight ahead running even at high speeds.

Drives

- Thermal component isolation of the motors, controller and pump and motor unit for optimal temperature characteristics and the best service access.
- Maintenance-free drives for travelling and steering with energy recovery when braking. Two three-phase drives provide powerful acceleration and braking.
- Robust gearing design.

Brake system

- Maximum safety due to 3-way braking system with ABS function. Maintenance-free, high efficiency generator braking system when the drive pedal is not actuated. Electro-magnetic brake as an emergency stop and parking brake. A brake regulator also comes into effect with increased braking, and prevents the wheels from locking.

Electrical equipment

- LCD display with automatic brightness control. Comfortable, operator friendly display of all operating states.
- Truck controller with 5 driving profiles. Parameters for travel speeds, acceleration and braking characteristics can be set independently of travel direction, individually to driver requirements, and to suit warehouse conditions.
- Electrical hoist cut-out protects the mechanism and the pump and motor unit.
- Speed regulation dependent on the steering angle (CSC – Curve Speed Control). A high level of safety for less experienced drivers and fragile goods.

Battery

- Truck centre of gravity improved by 30% and driver's compartment enlarged by 25% thanks to a unique battery concept. This gives the highest stability and best performance on bends.
- Battery can be picked up from the side by forks ensuring simple battery changes with great safety.
- High availability thanks to battery capacities up to 1000 Ah.

Service

- Easy removal of the covers provides quick access for service of the major assemblies.
- Access to the controller is provided conveniently from the driver's compartment.
- No lifting components under the chassis.

Equipment overview

		STILL	STILL
	Manufacturer		
	Manufacturer's model designation	FU-X 20	FS-X 33
	Rated capacity	2000 kg	3300 kg
Driver's compartment	Comfort seat with hydraulic damping and weight and longitudinal adjustment	●	●
	Driver's seat with heater	-	○
	Driver's seat with leatherette seat	-	○
	Arm to the left of the driver's seat	-	○
	Adjustable height footplate	●	●
	Electric thermostatically regulated foot heater	-	○
	Joystick for lifting/lowering, direction selection and horn	○	●
	Multifunction control for lifting/lowering/direction selection and horn	●	-
	5 Driving profiles, selected by driver	-	●
	Integral storage facilities, drink holder	-	●
	Display: Clear display of active operating states	-	●
	Combi-Instrument: Work hour meter and Battery state indicator	●	-
	Reading lamp	-	○
	Writing surface with clip	○	●
Steering	Fully electric steering 360°	-	●
	Fully electric steering 180°	●	-
	Fully electric steering with reverse function	○	○
	Redundant steering safety system	●	●
Drive unit	Smooth stepless acceleration to maximum speed	●	●
	Maintenance-free, totally enclosed drive unit	●	●
	Speed reduction dependent on steering angle	●	●
	Speed reduction dependent on load	●	-
	Individual parameter setting facilities	●	●
	Integral flow and temperature sensors for function monitoring	●	●
	Electrical hoist cut-out	●	●
Brake	Good Service access, simple diagnosis through central diagnostics interface	●	●
	Generator braking system	●	●
	Energy recovery when braking	●	●
	ABS Brake function	●	●
Battery	Electro-magnetic disc brake as parking brake and emergency stop	●	●
	Battery changing from the side with forklift truck	-	●
	Battery changing from the side with roller track	●	-
	Battery compartment for 360 Ah-560 Ah	●	-
	Battery compartment for 930 Ah-1000 Ah	-	●
	Side battery cover	●	○
Additional equipment	Battery changing frame	○	-
	Various fork lengths	○	○
	Preparation for data terminal	○	○
	Wind shield on 3 sides, open towards the forks	-	○
	Cold store version	○	○
	Comfort cold store cab, heated	-	○
	PIN-Code access, keyless, with button	○	○
	FleetManager: Access authorisation, accident recorder	○	○
Acoustic driving warning signal (Digisound)	○	○	

● Standard ○ Option - Not available



STILL



STILL Materials Handling Ltd
Aston Way
Leyland Preston
PR26 7UX
Tel.: +44 (0)845 603 6827
Fax: +44 (0)1772 454668

STILL Materials Handling Ltd
19 Hennock Road
Marsh Barton Trading Estate
Exeter
EX2 8RU
Tel.: +44 (0)1392 435151
Fax: +44 (0)1392 824328
info@still.co.uk

For further information please visit:
www.still.co.uk



STILL is certified in the following areas: Quality management, occupational safety, environmental protection and energy management.



first in intralogistics